

## Moving Head 15R

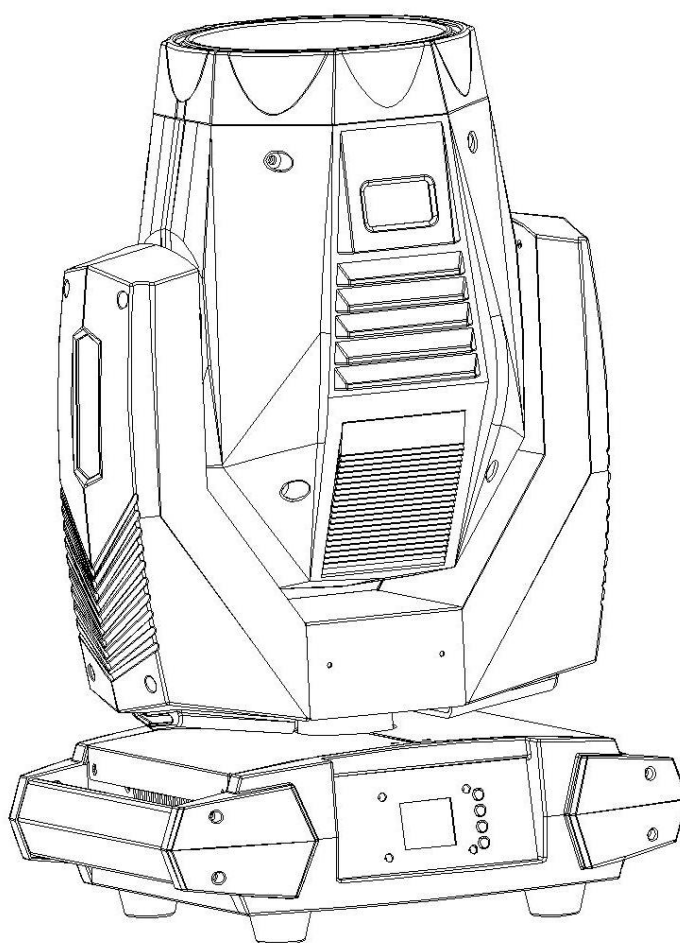

## User Manual

# CATALOG

1:SAFETY INSTRUCTIONS-----	3-4
2: TECHNICAL PARAMETERS-----	5
3:SCHEMATIC LIGHTING COMPONENTS-----	6
4:PACKING AND SHIPPING-----	7-8
5:SAFETY STANDARD INSTALLATION-----	8-11
6:AC POWER-----	11
7:LAMP-----	11-12
8:FUNCTION-----	12-14
9:DISPLAY SETTING-----	14-19
10:CHANNELS-----	19-22
11:TROUBLE SHOOTING & SOLUTION-----	22-23
12.FIXTURE CLEANING-----	23
13.PHOTOMETRICS DIAGRAM-----	24

## 1:SAFETY INSTRUCTIONS

Please carefully read the instructions, this guide consists of important information about installation, using and maintenance.

◇ Before using this product, please carefully observe the product is not unwrapped or damage during transport. In case of damage caused by transportation, please do not use this product and as soon as possible contact your dealer.

- ◇ It is very important that connecting the ground wire to avoid electric shock.
- ◇ This product is for dry indoor environments.
- ◇ This product must be installed on the sufficient space, adjacent to interface the shortest distance of 50cm, to ensure that the lights will not crash each other.
- ◇ Before moving or repairing the product, please keep the power off.
- ◇ When it working, ensure that no inflammable and explosive near the product.
- ◇ When installing this product, please use the safety rope. When handling this product, lift the armrest base, rather than the lamp body.
- ◇ The product is suitable for a maximum temperature of 40 degrees Celsius. When the surrounding environment is higher than 40 degrees Celsius, please do not use this product.
- ◇ Do not touch. In operation, the product running very fast, to prevent bumps hands.
- ◇ If there is a problem with the operation during the show, the lighting should be stopped immediately. Do not perform repairs, damage or repairs that may occur during maintenance. Please contact the company's after sale for repair. Use the same model of accessories during the repair process.
- ◇ Please carefully read the instructions, this guide consists of important information about installation, using and maintenance. It is important that the product must have anti-vibration protection carton or flight case during transportation.

## 2. TECHNICAL PARAMETERS

- ◇ DMX Channel: 16 Channels
- ◇ Control Mode: DMX512 Mode, Auto Mode
- ◇ LED LCD Display + Press button
- ◇ Original Osram 310W bulb + Electronic Ballast
- ◇ Pan & Tilt Motor: Ultra mute and high speed 3-Phase step motors
- ◇ Color temperature: 8000K, life span is 4000 hours
- ◇ 13 Colors + Open, Semi Color Effect
- ◇ 9 Fixed Gobo + 5 Open
- ◇ Prism: 8-Facet Prism and honeycomb prism could rotate reversible, prisms can combine multilayer beam effect.
- ◇ Optical lens: High precision glued optical lens
- ◇ Frost Angle: 8°
- ◇ Focus: Linear Focus
- ◇ Dimmer: 0-100% linear dimmer
- ◇ Beam angle: 0-2.3 degree
- ◇ Strobe: Electronic Strobe (0.5-9FPS)
- ◇ Housing: High temperature resistant alloy plastic+plastic handle
- ◇ Rated Power: 400W
- ◇ IP Rate: IP20
- ◇ Weight: 15.6KG
- ◇ Size: 361\*261\*527mm

# 3:Schematic Lighting Components

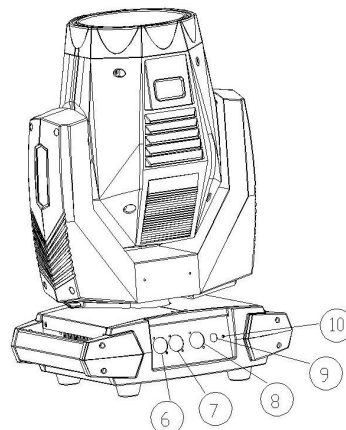
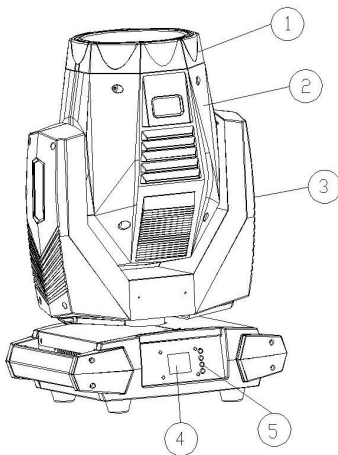
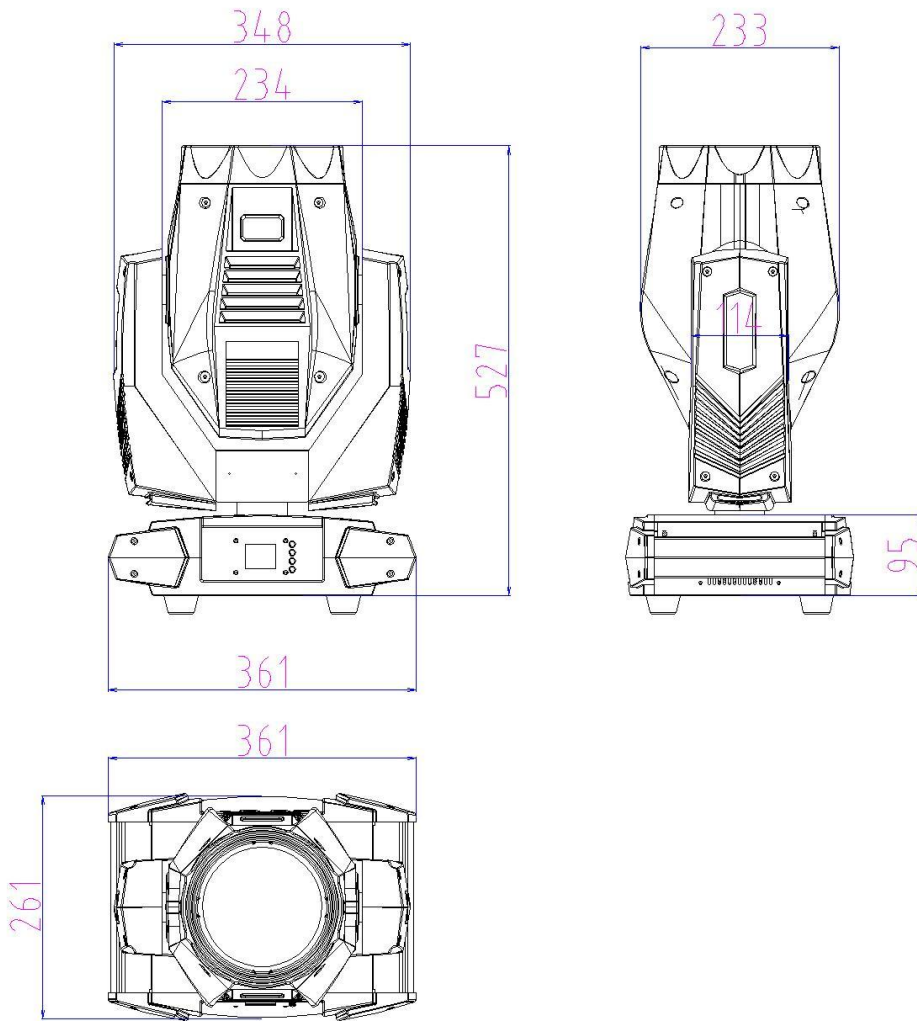

1. Lens Front Cover

2. Lamp Body Cover

3. Light Arm

4. Display

5. Press Button

6:3-pin XLR DMX input

7:3-pin XLR DMX output

8:Power In

9:Fuse

# 4:Packing And Shipping

## 4.1 Packing

310 Beam light is packaged by carton or standard 2in1 flight case(selectable 1in1 or 4in1), accessories items are as below

Name	Quantity	unit
User manual	1	piece
Signal line	1	piece
safe rope	1	piece
Hanging lamp hook and fastener	2	piece
Power line	1	piece

## 4.2 Transport protection locks

In order to transport it easy to protect the lamp body has two locks(XY axes each a lock), X-axis has four lock position, Y-axis triple lock, lock locked in the center position in the transport and light a vertical position with the arm member.

## 4.3 Packing

- 1.Disconnect the power supply so that the lamp to cool completely before packaging equipment, at least 15 minutes or more.
- 2.Closing the light protect lock, when clean the surface of the light dust
- 3.Cover the light , seize the equipment both sides aluminum handles on to make it upside down and gently placed in the box.
- 4.Add lighting accessories after placing the light in box.
- 5.Up to two crates stacked prohibited upside down.

## 4.4 Unpacking

- 1.Open the box and bag

2. Seizing the equipment handles, lifting and carrying away the light from the box. Or opening the flight case cover, placing lift boom close to the light base, then equipping light hook on light base bottom.

Tightening Quick Install locks. At last rising away boom to the top of the lamp from flight case, put the flight case away.

3. Before turning on the light, should open the light protecting lock

**Note: Upon receipt of lamps, please check if there is damage to the fold closure caused by transport, where there is transportation damage, please do not use this fixture, and as soon as possible contact.**

## **5: Safety Standard Installation**

Users should ensure that light and installation materials are checked for regular safety checks, unprofessional incorrect installation can lead to dangerous, if the lack of working conditions and professional standards, please operate the light by professionals. Do not use the light if the working temperature isn't 15°-40°. When the lighting installation, dismantling, moving, or servicing, do not stand directly beneath the lamp. The operator must ensure that the fixtures are secure connection, installing the light after professionals approving electrical parameters, make sure that these installation must be checked at least once per year by experts.

### **5.1 Installing rigging**

Beam moving head lights can be placed on the stage or on a stand in any direction, Quick lock system can quickly and easily remove or install a light hook.

**Note: must use two clamps fixed equipment, and are 1/4 buckle fastening jig, only fully rotated 90 degrees clockwise to lock fastener.**

## 5.2 Fixed equipment

1. Before installing fixtures, must verified rigging equipments are not damaged, and can bear at least 10 times of light's weight. Check the building can be beared at least 10 times of total weights of light, fixture, and cable accessories.

2. Insert the locked hook fastener into base mounting holes horizontally, grab the handle clockwise 90 degrees fasteners, in the same way to install a second fastener, make sure the fastener is fastened under the light base.

3. If truss can be lifted, the equipment can be directly clamped from flight case and locked fixture base. Then hung on the light and using safety rope fixed it.

Before rising the light to right height, connect the power cord and signal cable.

**Note: add a safety rope attached the light's base insurance shelf, do not connect the device handle.**

**Lights be placed vertically upward, the shortest distance between working lights must be more than or equal 1000mm, lighting installation layout as following.**

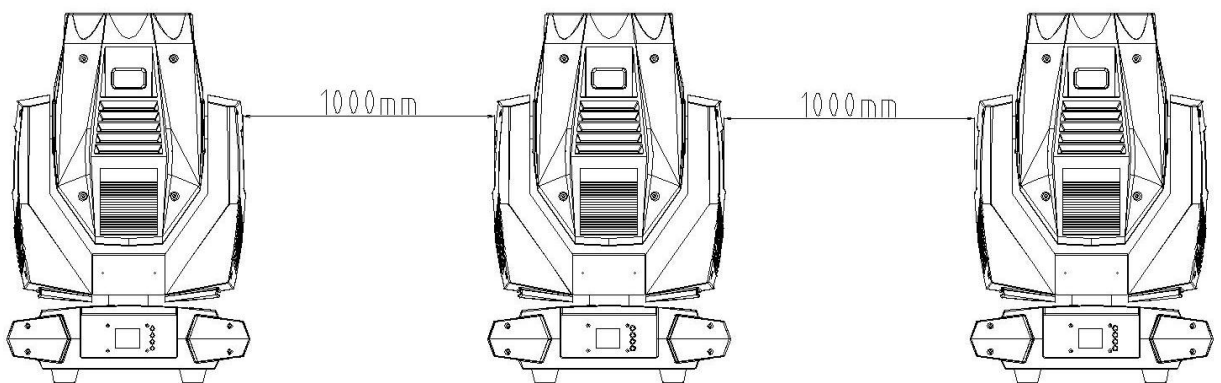

## 5.3 Data cable

Data cable is DMX512 signal

Note: Signal line connections is X-type connector。

X-type connector-----If the external flexible cable or cord of this light is damaged



and output connects to a three-pin XLR and five-pin XLR insert, first pin is grounded, then negative signal is second pin, third pin connects to the positive polarity signal, fourth and fifth are empty. In order to prevent reception reflection and interference control signal, a terminal plug must be installed on the first branch of the connected device last 3-pin output jack.

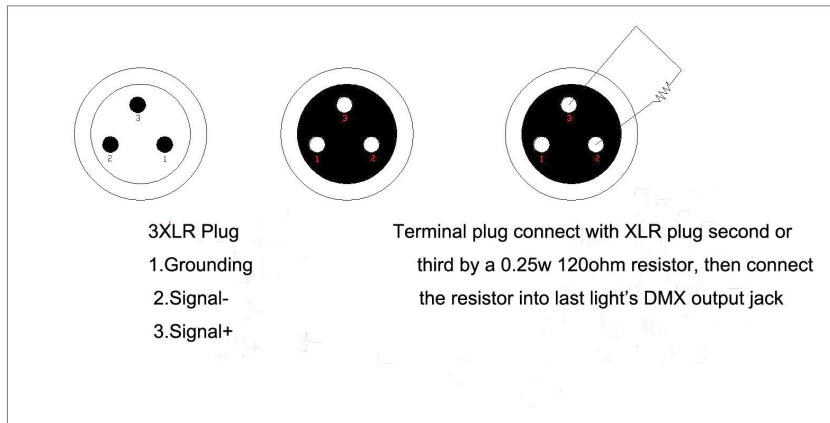

Connect the controller to the nearest input XLR 3-pin, then from the output of the device connects to the input of the next device, continuous connection one by one, the final output data cable terminal equipment plug one end into the terminal.

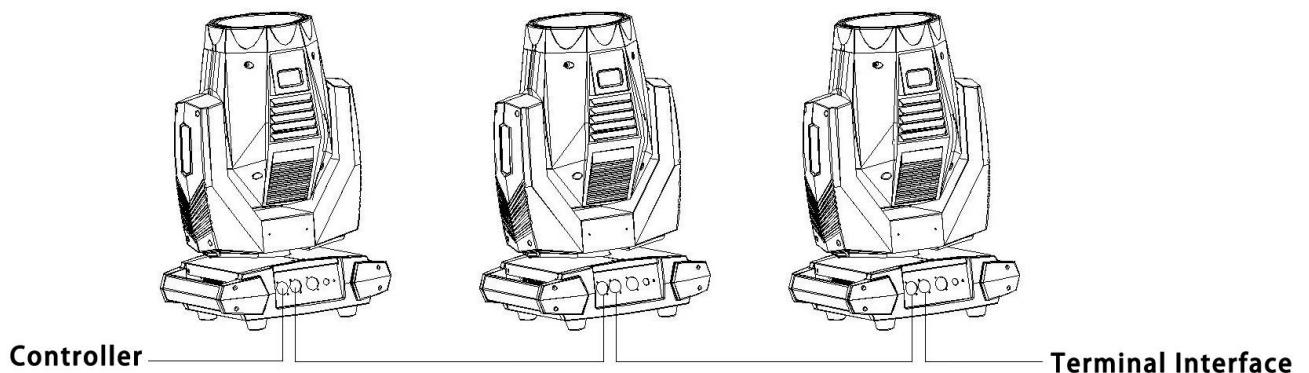

If the signal transmission is long-distance, 512 signal amplifier must be added. DMX512 signal controller connect to the input of the amplifier first, then connect to the fixture from its output, couple with the terminal plug last.

**1. Do not use two separate output connection, if connect the branch separating consecutive DMX512 signal amplifier must be used to separate.**

2. Please use the shielded twisted-pair cable, standard microphone cable can not be reliably controlled long-distance data.

## 6:AC POWER

### 6.1 Fuse

Power	Fuse
100-240v~	8A 5*20main fuse

### 6.2 Power Connection

If the external flexible cable or cord of this light is damaged, the line is up to the manufacturer or its service agent or a similar qualified person to replace, in order to avoid danger. Connect the power supply personnel must have the appropriate qualifications before proceeding, you must make sure you are using the power supply voltage matches the voltage identified and have overload or leakage protection.

Directly connect the device to the power supply, do not connect to the silicon box dimming system, otherwise damage to the equipment.

## 7:LAMP

### 7.1 Lamp Description

Beam Moving Head Beam light is fitted with Osram Single-ended lamp is short arc point light source, and its color temperature is 9000K and very stable, CRI >90. Life span is over 4000 hours(according the using situation)

**NOTE: Do not install other similar lamps, and will cause safety hazards or equipment damage. To reduce the risk of damage to the lamp, replacing the lamp before the lamp life over. Do not use scratches and has damaged bulb.**

### 7.2 Lamp Replacement

in a horizontal position.

2 Split bulbs: Remove the cover which is written “split this cover to replace the lamp head cover”

3 Use a Phillips screwdriver to remove the fan two thumbscrews fixed side.

4 With the appropriate force to push down the bulb when the lamp cup beyond the edge of the stainless steel shrapnel, taking up the lamp.

5 Install the bulb is the opposite of the operation.

**NOTE: Install other similar lamps, and will cause safety hazards or equipment damaged.**

**Install and remove the bulb gently into the bulb, do not let the bulb touch its surrounding hard objects, to prevent damage to the bulb. Note that the light bulb is notched in the direction of the blower's blow outlet.**

### **7.3 Correcting the bulb**

(when leaving the factory, the bulb has been corrected. , If individual cases happened after the replacement of the bulb, you can follow this method)

1. Turn on the power to reset, use the menu or controller, light the bulb, and play a white light.
2. Use a screwdriver to open one side of the cover housing of the lamp body
3. Use a flat-head screwdriver to adjust the screws on the light bulb fixing bracket. Turn the screws clockwise or counterclockwise, and adjust the light bulb to the right or left.

## **8:FUNCTION**

### **8.1 Gobo wheel**

A metal gobo wheel is composed by 9 aluminum gobos + 5 white, which could also be custom made.

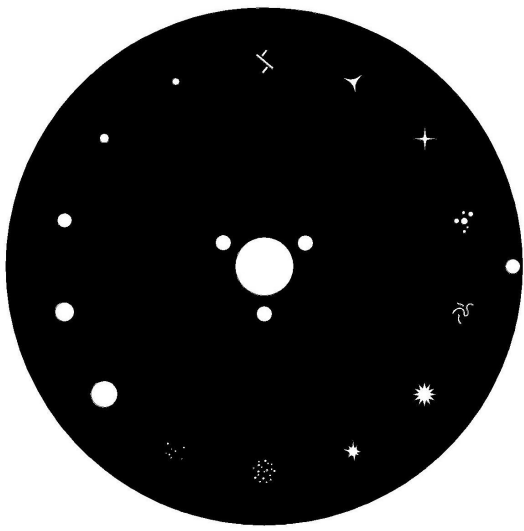

## **8.2 Color wheel**

Color wheel is made by 13 high standard fixed color, the user can easily select their own favorite color, to create a perfect lighting effect. Use the gobo wheel at same time is better. It can be easily transformed a colorful gobo effect. (According to customer needs may change at any time own custom various color wheel).

## **8.3 Optical lens focusing**

The two high precision screw motors are used to work together to adjust optical lens to complete the pattern definition.

## **8.4 prism wheel and the prism overlay**

The prism wheel is equipped with a 8-facet prism and a honeycomb prism can clockwise and counterclockwise rotation, speed adjustable, with colors and patterns, it can create a variety of colorful lighting effects. The prism plate through two high precision super eight head screw motors to adjust cutting prism spot size and then react the dynamic effect of prism .

## **8.5 Dimming and strobe**

0-100% mechanical dimmer, you can instantly switch freely adjustable strobe speed up to 12 times / sec, along with random strobe special features.

## **8.6 Frost**

Frost is a piece of atomizing lens, according to the actual control to complete the frost effect as your want .

## 8.7 horizontal and vertical scanning

Pan:540°, Tilt 270°, With 16BIT precise positioning capabilities.

Horizontal and vertical speed is adjustable.

# 9:Display setting

## 9.1 Display panel

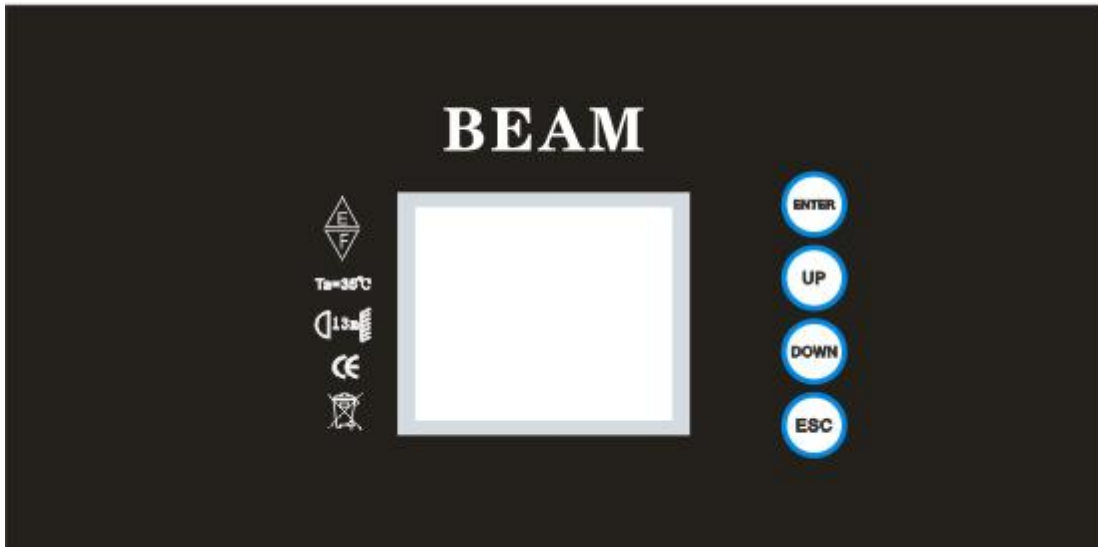

### BEAM MENU

1、 DMX Address: 1-512		
2、 Channel: 16Channels		
3、 Reset	Motor	ON/OFF
	XY	
	Shutter	
	Color	
	Gobo	
	Light Road	
4、 Operation	DMX / AUTO / USER	
5、 Lamp	ON/OFF	
6、 Manual Control	X	0-255
	Y	0-255
	XY Speed	0-255
	Color	0-255
	Shutter	0-255
	Dimmer	0-255
	Gobo	0-255
	Prism 1	0-255
	Prism 2	0-255
	Prism Auto Rotate	0-255
Frost	0-255	

	Focus		0-255		
	Rainbow Effect		0-255		
7、Operation Setting	Master/Slave Mode	Master/Slave			
	XY Setting	1、 Manual Scanning	Yes/No		
		2、 X Direction	Yes/No		
		3、 Y Reverse	Yes/No		
		4、 Speed channel real-time	Yes/No		
	No Signal	Power On	In Middle		
		In Running	Keep		
	Lamp On	Yes/No			
			Step 01	Time	0-255
				Channel 1	0-255
				Channel 2	0-255
				Channel 3	0-255
				Channel 4	0-255
				Channel 5	0-255
				Channel 6	0-255
				Channel 7	0-255
				Channel 8	0-255
				Channel 9	0-255
				Channel 10	0-255
				Channel 11	0-255
				Channel 12	0-255
				Channel 13	0-255
				Channel 14	0-255
				Channel 15	0-255
			Channel 16	0-255	
			Step 02	Time	0-255
				Channel 1	0-255
				Channel 2	0-255
				Channel 3	0-255
				Channel 4	0-255
		Channel 5		0-255	
		Channel 6		0-255	
		Channel 7		0-255	
		Channel 8		0-255	
		Channel 9		0-255	
		Channel 10		0-255	
		Channel 11		0-255	
		Channel 12		0-255	
		Channel 13		0-255	
		Channel 14		0-255	
		Channel 15		0-255	
		Channel 16	0-255		
		Step 03	Time	0-255	
			Channel 1	0-255	
			Channel 2	0-255	
			Channel 3	0-255	
			Channel 4	0-255	
			Channel 5	0-255	
	www.lucasled.gr				

						Channel 6	0-255	
						Channel 7	0-255	
						Channel 8	0-255	
						Channel 9	0-255	
						Channel 10	0-255	
						Channel 11	0-255	
						Channel 12	0-255	
						Channel 13	0-255	
						Channel 14	0-255	
						Channel 15	0-255	
						Channel 16	0-255	
						Step 04	Time	0-255
							Channel 1	0-255
							Channel 2	0-255
							Channel 3	0-255
							Channel 4	0-255
							Channel 5	0-255
							Channel 6	0-255
							Channel 7	0-255
							Channel 8	0-255
							Channel 9	0-255
							Channel 10	0-255
							Channel 11	0-255
							Channel 12	0-255
							Channel 13	0-255
							Channel 14	0-255
							Channel 15	0-255
							Channel 16	0-255
						Step 05	Time	0-255
							Channel 1	0-255
							Channel 2	0-255
							Channel 3	0-255
							Channel 4	0-255
							Channel 5	0-255
							Channel 6	0-255
							Channel 7	0-255
							Channel 8	0-255
							Channel 9	0-255
							Channel 10	0-255
							Channel 11	0-255
							Channel 12	0-255
							Channel 13	0-255
							Channel 14	0-255
							Channel 15	0-255
							Channel 16	0-255
						Step 06	Time	0-255
							Channel 1	0-255
							Channel 2	0-255
Channel 3	0-255							
Channel 4	0-255							
Channel 5	0-255							

						Channel 6	0-255	
						Channel 7	0-255	
						Channel 8	0-255	
						Channel 9	0-255	
						Channel 10	0-255	
						Channel 11	0-255	
						Channel 12	0-255	
						Channel 13	0-255	
						Channel 14	0-255	
						Channel 15	0-255	
						Channel 16	0-255	
						Step 07	Time	0-255
							Channel 1	0-255
							Channel 2	0-255
							Channel 3	0-255
							Channel 4	0-255
							Channel 5	0-255
							Channel 6	0-255
							Channel 7	0-255
							Channel 8	0-255
							Channel 9	0-255
							Channel 10	0-255
							Channel 11	0-255
							Channel 12	0-255
							Channel 13	0-255
							Channel 14	0-255
							Channel 15	0-255
							Channel 16	0-255
						Step 08	Time	0-255
							Channel 1	0-255
							Channel 2	0-255
							Channel 3	0-255
							Channel 4	0-255
							Channel 5	0-255
							Channel 6	0-255
							Channel 7	0-255
							Channel 8	0-255
							Channel 9	0-255
							Channel 10	0-255
							Channel 11	0-255
							Channel 12	0-255
							Channel 13	0-255
							Channel 14	0-255
							Channel 15	0-255
							Channel 16	0-255
						Step 09	Time	0-255
							Channel 1	0-255
							Channel 2	0-255
Channel 3	0-255							
Channel 4	0-255							
Channel 5	0-255							



						Channel 6	0-255	
						Channel 7	0-255	
						Channel 8	0-255	
						Channel 9	0-255	
						Channel 10	0-255	
						Channel 11	0-255	
						Channel 12	0-255	
						Channel 13	0-255	
						Channel 14	0-255	
						Channel 15	0-255	
						Channel 16	0-255	
						Step 10	Time	0-255
							Channel 1	0-255
							Channel 2	0-255
							Channel 3	0-255
							Channel 4	0-255
							Channel 5	0-255
							Channel 6	0-255
							Channel 7	0-255
							Channel 8	0-255
							Channel 9	0-255
							Channel 10	0-255
							Channel 11	0-255
							Channel 12	0-255
							Channel 13	0-255
							Channel 14	0-255
							Channel 15	0-255
							Channel 16	0-255
						Step 11	Time	0-255
							Channel 1	0-255
							Channel 2	0-255
							Channel 3	0-255
							Channel 4	0-255
							Channel 5	0-255
							Channel 6	0-255
							Channel 7	0-255
							Channel 8	0-255
							Channel 9	0-255
							Channel 10	0-255
							Channel 11	0-255
							Channel 12	0-255
							Channel 13	0-255
							Channel 14	0-255
							Channel 15	0-255
							Channel 16	0-255
						Step 12	Time	0-255
							Channel 1	0-255
							Channel 2	0-255
Channel 3	0-255							
Channel 4	0-255							
Channel 5	0-255							

			Channel 6	0-255			
			Channel 7	0-255			
			Channel 8	0-255			
			Channel 9	0-255			
			Channel 10	0-255			
			Channel 11	0-255			
			Channel 12	0-255			
			Channel 13	0-255			
			Channel 14	0-255			
			Channel 15	0-255			
			Channel 16	0-255			
			2、 Record DMX	Choose Step	0-12		
				Time	0-255		
Record							
3、 All Cleaning							
8、 Advanced Setting	Fine	X	-300-300				
		Y	-300-300				
		Color	-300-300				
		Gobo	-300-300				
		Dimmer	-300-300				
		Prism 1	-300-300				
		Prism 2	-300-300				
		Focus	-300-300				
		Rainbow Effect	-300-300				
		Prism Half-Step fine	-300-300				
		Prism 1 Half-Step fine	-300-300				
		Prism 2 Half-Step fine	-300-300				
	Frost Half-Step fine	-300-300					
	Display	Overturn	Yes/No				
Language	Chinese/English						
Ignore Errors	Code disk waveform	Yes/No					
Fine Recovery							
9、 Information	DMX Value						
	Mistake	Used Time					
		Time Clear					
	Test Mode	Fan Test					
XY Speed							

## 10. Channel

Mode/Channel	DMX Value	description
16		
1		<b>Color Wheel</b>
	0-4	White
	5-9	White + Red
	10-13	Red
	14-18	Red + Deep Yellow

	19-22	Deep Yellow
	23-27	Deep Yellow + Green
	28-31	Green
	32-36	Green + Yellow Green
	37-40	Yellow Green
	41-45	Yellow Green + Blue
	46-49	<b>Blue</b>
	50-54	Blue + Rose Red
	55-58	Rose Red
	59-63	Rose Red+Light Blue
	64-67	Light Blue
	68-72	Light Blue+Light Yellow
	73-76	Light Yellow
	77-76	Light Yellow + Purplish Red
	82-85	Purplish Red
	86-90	Purplish Red + Brownish Yellow
	91-94	Brownish Yellow
	95-99	Brownish Yellow + Brown
	100-103	Brown
	104-108	Brown + Cold White
	109-112	Cold White
	113-117	Cold White+Deep Blue
	118-121	Deep Blue
	122-127	Deep Blue+White
	128-190	Counterclockwise rainbow effect, from fast to slow
	191-192	rainbow effect stop
	193-255	Clockwise rainbow effect, from slow to fast
<b>2</b>		<b>Shutter</b>
	0-3	Close
	4-103	Shutter from slow to fast
	104-107	open
	108-157	Fast open slow close,from slow to fast
	158-207	Fast close slow open, from fast to slow
	208-212	open
	213-251	Random shutter, from slow to fast
	252-255	Open
<b>3</b>		<b>Dimmer</b>
	0-255	0-100% Dimmer
<b>4</b>		<b>Gobo</b>
	0-3	white
	4-9	Gobo1
	10-15	Gobo2
	16-21	Gobo3
	22-27	Gobo4
	28-33	Gobo5
	34-39	Gobo6
	40-45	Gobo7
	46-51	Gobo8

	52-57	Gobo9
	58-63	Gobo10
	64-69	Gobo11
	70-75	Gobo12
	76-87	Gobo13
	88-95	Gobo1: Shake from slow to fast
	96-103	Gobo2: Shake from slow to fast
	104-111	Gobo3: Shake from slow to fast
	112-119	Gobo4: Shake from slow to fast
	120-127	Gobo5: Shake from slow to fast
	128-135	Gobo6: Shake from slow to fast
	136-143	Gobo7: Shake from slow to fast
	144-151	Gobo8: Shake from slow to fast
	152-159	Gobo9: Shake from slow to fast
	160-167	Gobo10: Shake from slow to fast
	168-175	Gobo11: Shake from slow to fast
	176-183	Gobo12: Shake from slow to fast
	184-191	Gobo13: Shake from slow to fast
	192-201	Empty
	202-227	Gobo Flow clockwise, from fast to slow
	228-229	Stop
	230-255	Gobo Flow Counterclockwise, from fast to slow
<b>5</b>	<b>1-255</b>	<b>Rainbow effect</b>
<b>6</b>		<b>Prism</b>
	0-63	No Prism
	64-127	Prism 1
	128-191	Prism 2
	192-255	Prism 1 + Prism 2
<b>7</b>		<b>Prism macro effect</b>
	0-15	Nothing
	16-55	Prism 2 shake from slow to fast,prism 1 disappear
	56-95	Prism 1 shake from slow to fast,prism 2 disappear
	96-135	Prism 2 shake from slow to fast,prism 1 activate
	136-175	Prism 1 shake from slow to fast,prism 2 activate
	176-215	Prism 1 + Prism 2 shake together, from slow to fast
	216-255	Prism 1 and prism 2 shake interactively from slow to fast, overlapping
<b>8</b>		<b>Prism 1 and Prism 2 Positioning and Rotating</b>
	0-127	Prism 1 Positioning and Rotating
	128-190	Prism 1 rotates in reverse, from fast to slow
	191-192	Prism 1 stop rotating
	193-255	Prism 1 rotates forward, from slow to fast

<b>9</b>		<b>Frost</b>
	0-1	No Frost
	1-255	Frost
<b>10</b>		<b>Focus</b>
	0-255	Focus from far to near
<b>11</b>		<b>Pan</b>
	0-255	Pan Rotate
<b>12</b>		<b>Pan Fine</b>
	0-255	Pan Fine
<b>13</b>		<b>Tilt</b>
	0-255	Tilt Rotate
<b>14</b>		<b>Tilt Fine</b>
	0-255	Tilt Fine
<b>15</b>		<b>Pan/Tilt Speed</b>
	0	Max Speed
		Speed Mode
	1-255	Speed from fast to slow
		Time Mode
	1-255	Time from 0.1 second to 25.5 second
<b>16</b>		<b>Function</b>
	To achieve the following effect, push the DMX value to the appropriate position and keep for at least 4 seconds	
	0-99	Empty
	100-109	Pan/Tilt reset
	110-119	Function Reset
	120-129	All Reset
	130-159	Empty
	160-191	Lamp Off
	192-229	Empty
	224-255	Lamp On

## 11:FAILURE SCOREBOARD AND SOLUTIONS

Listed below is a common approach in the operation of a few common problems.

◇ Fault A: The lamp is not working, the bulb is not lit, the fan does not work

Solving 1: Check the power supply or the fuse is burned.

Solve 2: The main power connector on the voltage detector.

◇ Fault B: connect control units, lighting does not respond

Solving 1: After connecting control units, lighting should be working. If it is not working properly, check the signal cable plugs and wires are connected correctly.

Solve 2: If the lamp is lit display, but the channel does not respond, check the address code is set correctly and DMX output voltage polarity.

Solve 3: DMX signal problems if your lighting is off, check the input terminal and the circuit board.

Solve 4: Please change another one DMX controller.

Solve 5: Check whether the signal cable near high voltage power lines caused DMX display board inside the wire damage.

◇ Fault C: some channel is not working

Solving 1: stepper motor may be damaged, or the line connecting the motherboard burned out.

Solve 2: IC driver board on the motherboard may be damaged.

## 12: CLEAN LIGHTS

The cleaning of internal and external optical lenses and/or mirrors must be carried out periodically to optimize light output.

Cleaning frequency depends on the environment in which the fixture operates: damp, smoky or particularly dirty surrounding can cause greater accumulation of dirt on the unit's optics.

Clean with soft cloth using normal glass cleaning fluid.

Always dry the parts carefully.

Clean the external optics at least every 20 days. Clean the internal optics at least every 30/60 days.

Clean the fans on the head and base every 20 days.

Disconnect the fixture before clear.

# 13. 15R BEAM Illumination

## BEAM ILLUMINATION

